

OSCAR MINI, MINI D, MINI W, DAVIDA MINI

Installation Manual

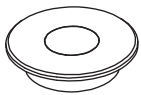

OSCAR MINI RD

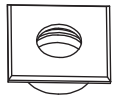

OSCAR MINI SQ



OSCAR MINI D



OSCAR MINI W
1 WAY



OSCAR MINI W
2 WAY



OSCAR MINI W
3 WAY



OSCAR MINI W
4 WAY



DAVIDA MINI

Installation WITH Mounting Box (ACR.158)

1



Attention

Before any maintenance switch off the main power.

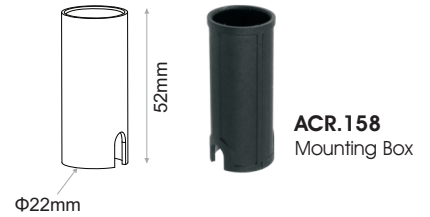
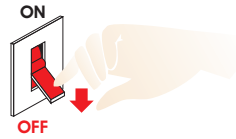

ACR.158
Mounting Box

2

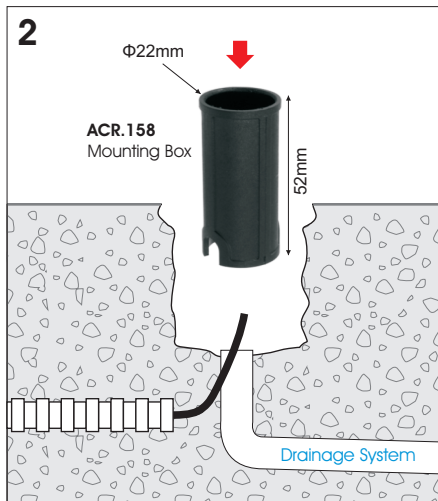

3

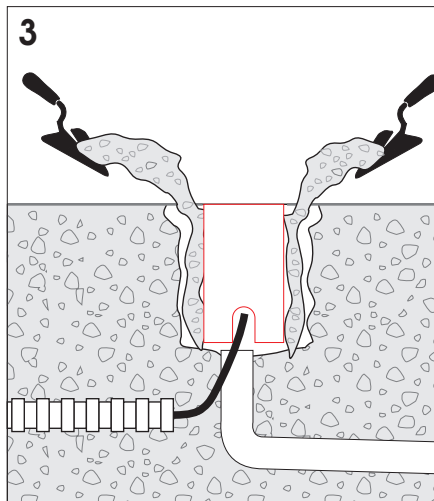

4

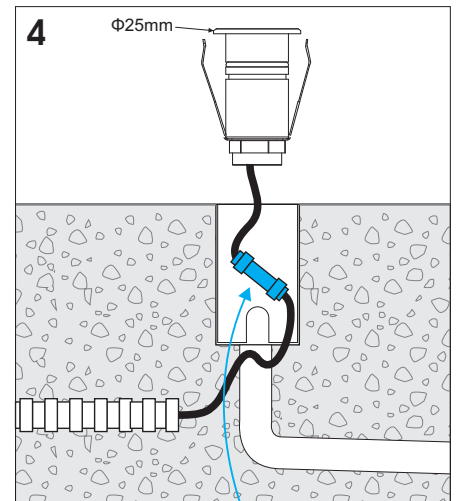

For cable connection you must use IP68 connectors or junction box.

5

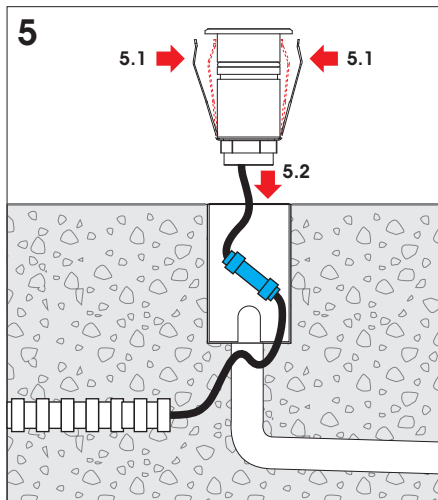

6

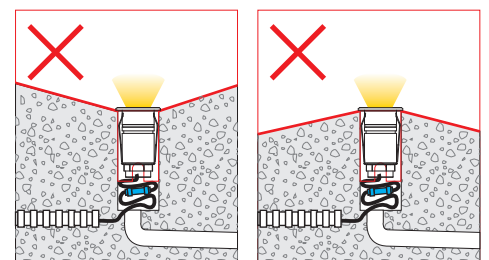
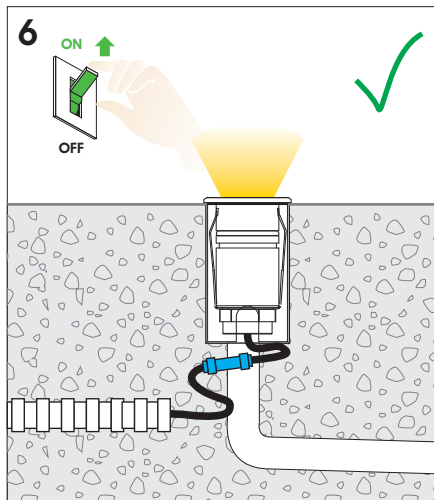

Installation WITHOUT Mounting Box (ACR.158)

1

Attention
Before any maintenance switch off the main power.



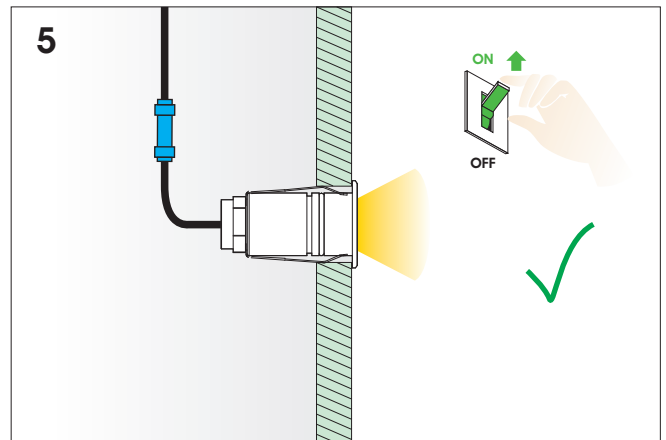
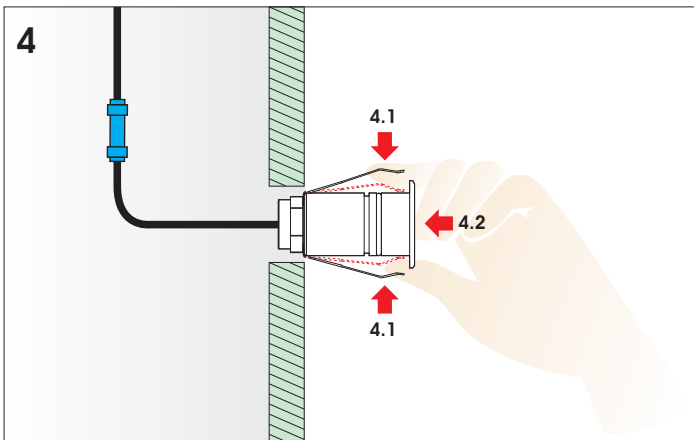
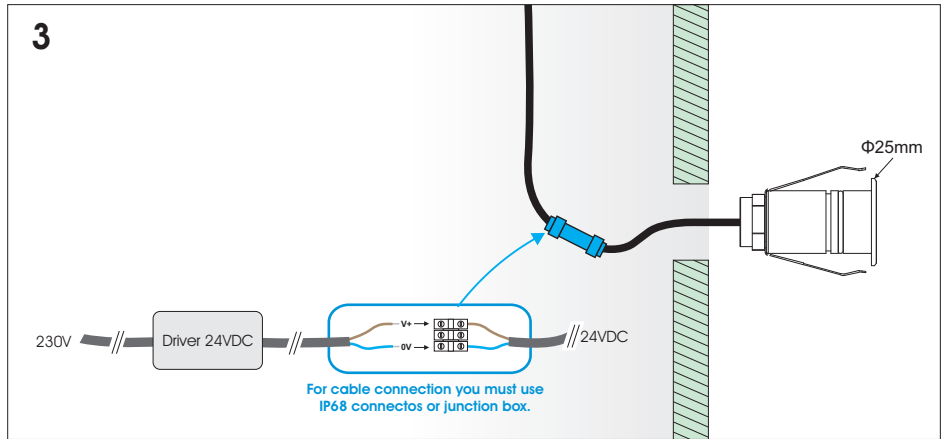
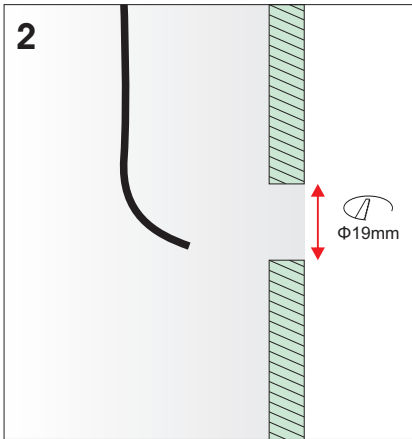

Connection Diagram

- > This LED luminaire must be connected to a constant voltage converter 24VDC. WARNING! Incorrect connection may damage the luminaire.
- > Connect the LED luminaire to the converter before the converter is connected to the power source.

